

OPERATOR'S MANUAL SBAXXS-XSS-TX

INCLUDING: OPERATION, INSTALLATION & MAINTENANCE

Released: 20 Nov 2013

1/2" and 1" Pulsation Dampener

**READ THIS MANUAL CAREFULLY BEFORE INSTALLING,
OPERATING OR SERVICING THIS EQUIPMENT.**

It is the responsibility of the employer to place this information in the hands of the operator. Keep for future reference.



INGERSOLL RAND COMPANY

6 AVENUE GUTENBERG, 77600 BUSSY-SAINT-GEORGES – FRANCE

WWW.INGERSOLLRANDPRODUCTS.COM

ARO[®]

IR Ingersoll Rand[®]

Introduction & Description:

Preliminary remarks

ARO pulsation dampeners are designed in accordance with current industrial standards. Misuse or abuse may result in danger, which may lead to personal and / or property injury. The pulsation dampener should be used only for the intended use and should always be in perfect condition.

Read and follow the instruction in this manual carefully to ensure trouble-free and efficient operation of the pulsation dampener. This manual gives the operator detailed information about installation, operation and maintenance of the pulsation dampener

Description of the product, intended use, operation and potential risks!

ARO Pulsation dampeners are used for an efficient reduction of fluid pulsation (pressure and flow rate variation) in the piping system during air operated diaphragm pump operation. The ARO pulsation dampener is designed to work only with 1:1 ratio pumps having an outlet pressure not exceeding 10 bar. The pulsation dampener will effectively reduce material pressure variations, surges and shock to piping and delivery in fluid systems during pump reversal. It can significantly contribute to pulse reduction in low pressure spray applications.

The dampener works with its own compressed air connection and a diaphragm that automatically adapts to the given pressure conditions and thus reduces the pulsation optimally.

This product can be used in explosive environment (ATEX zone 1, 2, 21, 22) outside or inside building.

The pulsation dampener uses a single air pressurized flexible bladder working against the fluid line pressure.

Two bladder material options are available to allow custom matching to the fluid material for best compatibility (refer to the model description chart).

The use of a pulsation dampener for a higher level of automatic pressure adjustment and accuracy is important.

It uses a sensing rod to detect the position of the diaphragm and an automatic air valve to adjust the airline pressure or to exhaust excessive pressure in the diaphragm chamber as needed. An air pressure gauge is standard to monitor the air side internal chamber pressure. Pulsation dampener can also be added in series to provide additional dampening on the material.

WARNING: The intended use of a pulsation dampener is therefore after a pump, on the pressure side of the fluid being pumped under the conditions specified in this manual, under operating parameters and in compliance with the prescribed conditions for commissioning, operation, assembly, disassembly and maintenance.

WARNING: Even when all the necessary installation and safety measures have been taken in accordance to the description in this manual, there is a residual risk through leaks or mechanical damage. Liquid can escape uncontrollably at gaskets or connections level.

Model Description Chart

SBA XX S – XSS - TX

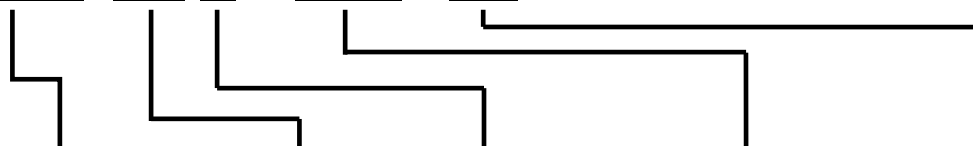

Pulsation dampener	Size	Air Section	Thread / Fluid section	Diaphragm Material
Automatic version	05 – ½" 10 – 1	Stainless Steel	A – NPT B – BSP F – Flange (only 1") Stainless steel Fluid section	TG – PTFE / NBR TA – PTFE / EPDM

ATEX Marking: II 2GD IIB

Device Group "II" = Product cannot be used in the mining industry

Device category "2GD" = Explosion proof for zone 1 and 21 & zone 2 and 22

Explosion group "IIB" = Parameter for the ignitability of used materials

"TX" = the maximum surface temperature depends on the fluid temperature.

The assignment of the temperature class for maximum surface temperature according to DIN EN 13463-1 is shown below:

Class of Temperature	Maximum surface temperature [°C]
T1	450
T2	300
T3	200
T4	135
T5	100
T6	85

The pulsation damper is subject to the Pressure Equipment Directive 97/23/EC article 3 (3). The design, manufacture and testing of the products is carried out according to "Good engineering practice".

Operating and Safety Precautions

READ, UNDERSTAND AND FOLLOW THIS INFORMATION TO AVOID INJURY AND PROPERTY DAMAGE.

WARNING: Installation, operation and maintenance of the pulsation dampener must be done only by **qualified staff** that can read and understand the manual.

WARNING: **Explosion hazard. Do not exceed maximum fluid inlet pressure of 10 bar.** Operating at higher pressure can cause explosion, resulting in property damage or severe injury.

WARNING: **Use only with compressed air. Do not use bottled gas products to run the Shock Blocker.** Unregulated high pressure bottled gas has the potential for over-pressurization. Certain gasses, such as Nitrogen, can cause unpredictable results. The pressure source **MUST BE REGULATED**.

WARNING: **Temperature limitations. Do not exceed maximum temperature limits of 82°C for NBR/PTFE diaphragm and 107°C for EPDM/PTFE diaphragm.** Excessive operating temperatures can weaken the body material. Limits are based on mechanical stress only.

WARNING: **Chemical compatibility hazard. Do not use with certain fluids.** Incompatible fluids may attack and weaken the housing, causing rupture or explosion, which can result in property damage or severe injury. For specific fluid compatibility, consult the chemical manufacturer.

WARNING: **Wear suitable protective clothing and glasses** before starting any work on the pulsation dampener.

WARNING: **Pools of liquid in the near outer area of the pulsation damper are to be checked for danger** before any contact. Chemical and biological reactions in the product space of the dampener or pump system (mixture of different substances) must be avoided.

WARNING: **Disassembly hazard. Do not disassemble this unit when it is under pressure.** Relieve all material pressure in the pumping system before attempting service or disassembly. Disconnect air lines and carefully bleed any pressure off the system. Be certain the system is not maintaining pressure due to a material restriction in the hose, line, dispensing device or the spray or extrusion tip. Failure to relieve pressure both upstream and downstream may result in an injury upon disassembly.

WARNING: **Material atomization. The relief / exhaust valve must be piped away from the work area.** In the event of a bladder rupture, the material can be atomized and forced out the relief / exhaust valve.

WARNING: Before attempting service or disassembly, be certain to disconnect the air supply and relieve fluid pressure. be certain the entire installation is shut off and cannot be accidentally switched on. in addition a warning label should indicate maintenance is in process and installation should not be reconnected.

WARNING: Use of non-original ARO replacement parts and/or structural changes to the products immediately invalidate the warranty and may result in a personal injury and / or property hazard in the operation of the dampener.

WARNING: Protect dampener, pump system and components from freezing

WARNING: In case of diaphragm breakage, fluid can together with air escape from the air exhaust and cause severe injury. When pumping flammable or dangerous fluid, it is recommended to pipe the air exhaust away. Please consult us for air exhaust adapter.

CAUTION: Not for structural support. Do not use this product to support other system components or use as a step. Improper support can result in fracture of the housing, causing damage. Plumbing must be supported to prevent stresses upon it. Install using the mounting hardware supplied.

CAUTION: In case of diaphragm rupture in the dampener, the fluid may enter the air side of the pulsation damper. In worst cases, the fluid can penetrate the air supply line. For the protection of other components, it is recommended to protect the air system, for example, with a check valve.

CAUTION: Check the tightness of the flange bolts according to the manual regularly, in particular before first operation, after few hours of operation, or after longer downtimes period.

CAUTION: Inspect and service dampener regularly to avoid failures or fluid leakage.

CAUTION: Flush the Dampener and system regularly in case heavier particles may settle out. For larger solids a strainer / filter should be installed on the suction line of the pump.

NOTICE: Replacement warning label is available upon request.

WARNING = Hazards or unsafe practices which could result in severe personal injury, death or substantial property damage.

CAUTION = Hazards or unsafe practices which could result in minor personal injury, product or property damage.

NOTICE = Important installation, operation or maintenance information.

Installation and commissioning

WARNING: HEED WARNINGS AS SHOWN IN “OPERATING AND SAFETY PRECAUTIONS”.

WARNING: Use the dampener only in accordance with the operating values specified in technical data. Pulsation dampers are to be installed and connected without mechanical stress or stretch. Not observing this rule may result in leakage or damages. Before connecting, remove the protective caps from the fluid and air port. The operator has to ensure appropriate stability and state of the art installation of the fluid and pneumatic piping. The self-adjusting dampener can only be mounted on the discharge side of a pump. The distance to the pump should be as low as possible. In case the unit is mounted directly to the pump outlet, it should be independently mounted and plumbed using flexible tubing and not expected to physically support other components. The material flow should be in the direction of the pulsation dampener, for best results, not passing by at right angles.

For proper function, the active dampener absolutely requires its own compressed air supply, by using a T-piece before the air inlet of the connected pump. A check valve must be installed on this line in accordance to the

connection drawing. No gate or regulating valves should be mounted between the pump and dampener. Different materials affect the mounting configuration. For best performance and typical applications, mount the pulsation dampener upright versus horizontally. Heavier particles in some fluids may settle out. Gravity will help discharge heavier particles when mounted vertically.

CAUTION: In case of diaphragm rupture in the dampener, the fluid may enter the air side of the pulsation dampener. In worst cases, the fluid can penetrate the air supply line. For the protection of other components, **it is recommended to protect the air system, for example, with a check valve.**

WARNING: The ARO pulsation dampener is designed to work **only with 1:1 ratio pumps having an outlet pressure not exceeding 10 bar**

WARNING: Use a ground lug and grounding cable kit in applications where flammable fluids are used, to help guard against static spark hazard resulting in possible fire or explosion. The terminal on the end of the ground wire must be removed and the wire stripped back to be accepted by the pulsation dampener ground fitting.

Pump and dampener must be supplied with the same air pressure. The simultaneous use of several pumps for one pulsation dampener is not possible. Each pump requires a separate pulsation dampener, with which it builds a closed system. ARO pulsation dampeners must be operated with oil-free, clean and dry compressed air. Additional lubrication by oiler is not allowed. For trouble free operation, you need a minimum back pressure of approximately 1,5 bar. Start the system slowly when the pulsation dampener is empty. It adapts automatically to the operating conditions change of the pump. Please note that the use of a pulsation dampener reduces the overall flow capacity of the pump system.

AIR REQUIREMENTS: Clean, dry air should be used to charge the unit. A filter capable of filtering out particles larger than 50 microns should be used on the air supply.

WARNING: In the event of a bladder rupture, the material being pumped could leak from the exhaust port. Route the drain line to a location where escaping air, material or air containing atomized material will not harm personnel or property. Please consult us for air exhaust adapter.

Connection drawing

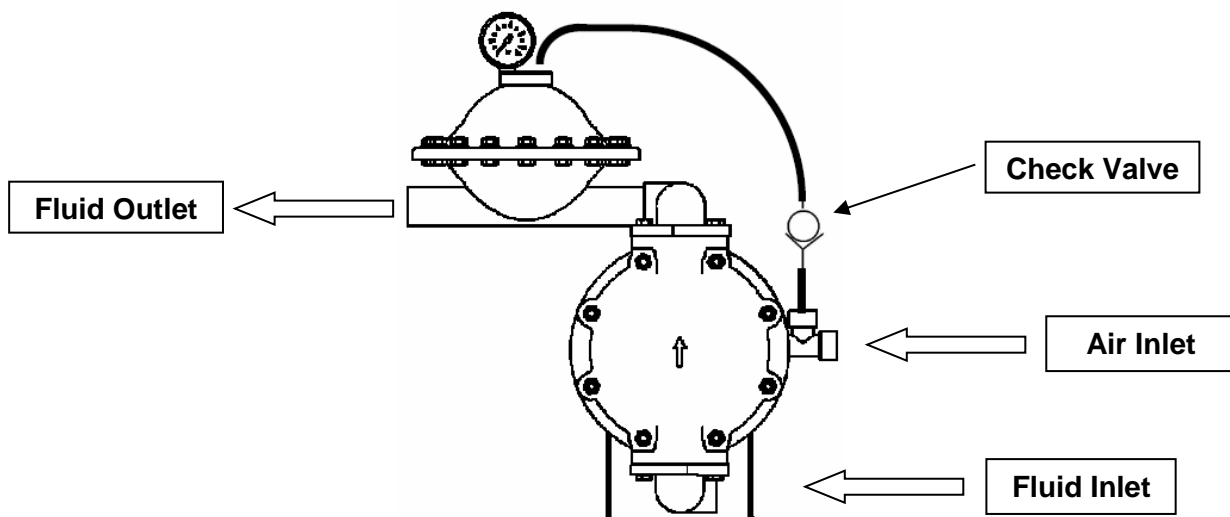

Operation

CAUTION: Do not exceed 10 bar maximum air inlet pressure supplied to the air inlet. Pressure relief through the exhaust port is a normal compensating function of the control valve in the air tamer. It will automatically adjust itself to the required operating pressure once the material pressure has been applied.

NOTE: The air pressure supplied to the air tamer needs to be equal to the material pressure to provide the proper dampening effect.

1. Connect a regulated air supply (10 bar maximum) to the air tamer inlet.

CAUTION: Air must be supplied to the air tamer before applying fluid pressure. Failure to pressurize with air first can damage the bladder.

2. Reconnect the air supply to the pumping system.

3. Operate the pump to generate material pressure.

4. Monitor the gauge for the air pressure needed to deliver the best pulsation dampening action.

5. Operate the system a few minutes between pressure adjustments, allowing for system equalizing.

CAUTION: Check the tightness of the flange bolts according to the manual regularly, in particular before first operation, after few hours of operation, or after longer downtimes period.

Daily inspection

- Check daily that there are no leakage of fluid from the joints and the exhaust plate.
- Check daily that no cracks or damage to the housing parts and piping have occurred.
- Check daily that the connections and piping are not loose.
- Check daily the exhaust plate for dirt and damage!

WARNING: If you find any error in the controls, the system must be shut down immediately and the mistakes must be rectified!

Service

WARNING: Before attempting service or disassembly, be certain to disconnect the air supply and relieve fluid pressure. be certain the entire installation is shut off and cannot be accidentally switched on. in addition a warning label should indicate maintenance is in process and installation should not be reconnected.

WARNING: Pulsation dampener which were used for aggressive, dangerous or toxic media are to disassembly only in accordance with the relevant additional safety requirement (eg appropriate protective equipment). Some fluid may remain into the dampener, despite intensive cleaning or flushing. Therefore appropriate protective clothing must be used at all time of the maintenance.

WARNING: If the pulsation dampener is returned to ARO, a duly completed declaration of decontamination is absolutely required. Otherwise, no diagnostic or maintenance can be completed.

WARNING: Use of non-original ARO replacement parts and/or structural changes to the products immediately invalidate the warranty and may result in a personal injury and / or property hazard in the operation of the dampener.

WARNING: Use appropriate tools, lifting equipment and protective equipment to prevent damages or injuries during transportation or repair

CAUTION: Wearing parts such as diaphragms and piston rod seals should be renewed regularly during preventive maintenance especially in application with critical fluids.

CAUTION: Relieving air pressure will not affect the fluid system pressure. the gauge reading could falsely represent any residual fluid pressure.

Troubleshooting

No dampening effect or erratic performance.

- Check for bladder rupture.
- Check for blocked or restricted outlet hoses.
- Check for a solid object lodged in the fluid inlet or in the bladder area.
- Check the air supply. Make certain the air pressure supply available to the tamer is equal to the fluid pressure. The air tamer will automatically adjust to the operating pressure.

Fluid or air leakage at the top.

- Check for bladder rupture.
- Check for defective pressure relief valve.
- Check for damaged "O" ring.
- Check the tightness of the flange bolts (16 Nm).

Cracks in the housing.

- Discontinue use. This would indicate possible fluid incompatibility with the Shock Blocker body material.

Disassembly

- To dismantle the pulsation dampener it is necessary to proceed as per the above procedures and safety rules. No special tools are required for disassembly and assembly.
- For part numbers, please refer to the spare parts list.
- Remove circlip (10)
- Remove plate (11)
- Remove second circlip (10)
- Use a wrench and turn left to remove the piston (5) from the diaphragm
- Untighten and remove nuts (8) and bolts (9) from the housing with a wrench
- Open the housing and remove the diaphragm (6)
- Remove piston rings (7) from the grooves carefully - Do not damage the edges of the valve. Re-use the same piston rings is impossible, they have to be replaced. Remove O-ring from the groove.



Check all components for damage and wear !
Clean or replace components if necessary !
Only use original ARO replacement parts!

Assembly

- Reassembly is as described above in reverse order. Below some additional information:
- Install a new piston ring (7) into the respective groove (note: groove 1, 3 and 5). Press the rings with a round object completely into the groove.
- Diaphragm (6) and the sealing surface of the housing must be absolutely clean and undamaged. Even small scratches can cause leaking (check carefully and eventually rework with fine sandpaper).
- Assemble diaphragm (6) and housing halves loosely, by means of bolts and nuts.
- Apply Loctite No 242 on the thread of the piston. See page 9
- Install the piston (5) in control valve (1a) and fully attach to the diaphragm. See torques on page 9
- Insert second circlip (10)
- Insert air exhaust plate (11)
- Insert first circlip (10)
- Assemble and tighten diaphragm and housing with screws and nuts evenly and crosswise. Use torque wrench to achieve torque value (page 9)

- Before putting the dampener back in operation, check for leaks
- All instructions listed in the chapter installation and commissioning and the safety instruction must be respected

Specification

Dampener Type: Active damping
 Housing material: Stainless steel 1.4571

Weight (kg) / Fluid chamber volume (liter)
 SBA05S-(A,B)SS-T(G,A) 3.4 kg / 0,6 l
 SBA10S-(A,B)SS-T(G,A) 3,5 kg / 0,65 l
 SBA10S-FSS-T(G,A) 4,1 kg / 0,65 l

Fluid inlet / outlets:
 SBA05S-BSS-T(G,A) ½ "BSP female
 SBA05S-ASS-T(G,A) ½ "NPT female
 SBA10S-BSS-T(G,A) 1 "BSP Female
 SBA10S-ASS-T(G,A) 1 "NPT female
 SBA10S-FSS-T(G,A) 1 "DIN flange

Air Inlet: 1/8 "BSP Female
 Pressure gauge: 1/8 "BSP Female
 Optional air exhaust: 1/8 "BSP Female

Maximum operating pressure at the air inlet: 10 bar
 Maximum operating pressure fluid inlet: 10 bar

Maximum operating temperature with PTFE / NBR Diaphragm: 4°C to 82°C
 Maximum operating temperature with PTFE / EPDM Diaphragm: 4°C to 107°C

Dimension (mm)

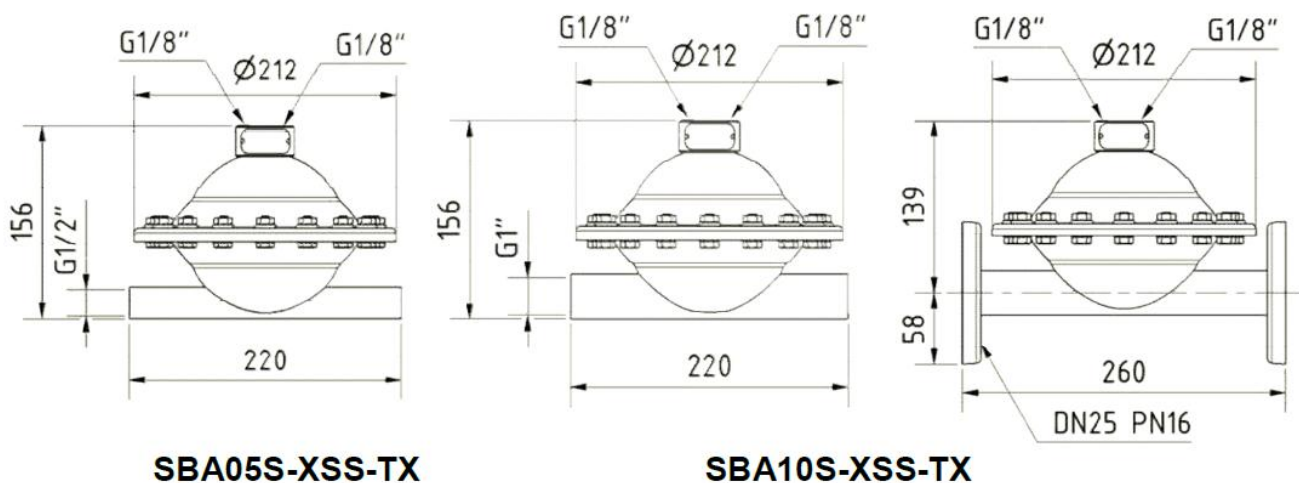

Note

In a plan view of the name plate:

- The compressed air supply is right , marked with a "1"
- The manometer connection is left

Part list

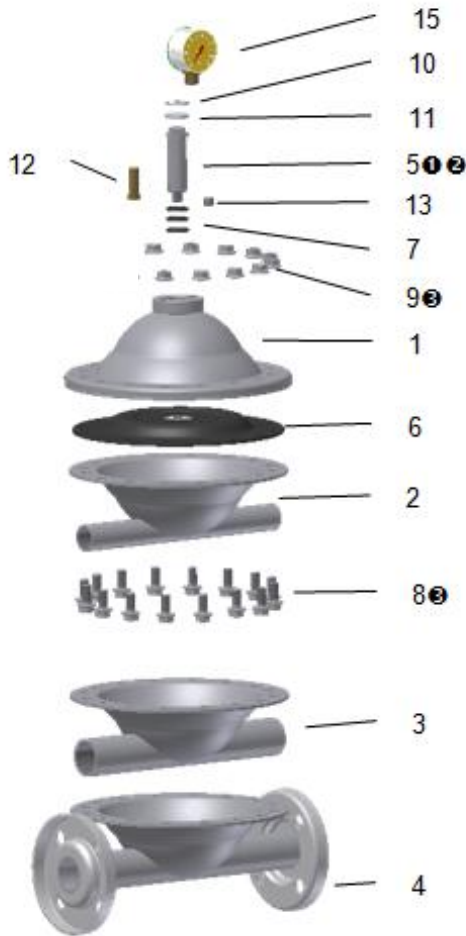

Recommended parts

Moving parts like diaphragm (6), Piston rings (7) and piston (5) are subject to wear even in regular operation. It is recommended to hold service inventory to avoid expensive downtime on your installation!

Ordering parts

To order parts, please always provide complete dampener part number and serial number!

Note:

- ② Tighten Screw (8) and Nut (9) crosswise with a torque of
 - 6 Nm in a first step
 - 16 Nm in a second step
- ① Apply grease on the surface of the piston (5)
- ② Apply Loctite 242 on Piston (5) thread and tighten with a torque of 10 Nm. Remove Loctite excess

Item	Quantity	Part	Description	Material	Used with:
1	1		Top Fluid Cap with valve	Stainless	All
2	1		Bottom Fluid Cap 1/2" BSP	Stainless	SBA05S-BSS-TX
2a	1		Bottom Fluid Cap 1/2" NPT	Stainless	SBA05S-ASS-TX
3	1		Bottom Fluid Cap 1" BSP	Stainless	SBA10S-BSS-TX
3a	1		Bottom Fluid Cap 1" NPT	Stainless	SBA10S-ASS-TX
4	1		Bottom Fluid Cap 1" Flange	Stainless	SBA10S-FSS-TX
5	1		Piston	Stainless	All
6	1		Diaphragm	PTFE / NBR	SBAXXS-XSS-
6a	1		Diaphragm	PTFE / EPDM	SBAXXS-XSS-
7	3		Piston Ring	PU	All
8	16		Screw	Stainless	All
9	16		Nut	Stainless	All
10	2		Circlip	Stainless	All
11	1		Exhaust plate	PE	All
11a	optional		Pipe Away Exhaust plate	Stainless	All
13	1		Cap Screw	Stainless	All
15	1		Manometer 0 – 10 bar		All

INGERSOLL RAND COMPANY

6 AVENUE GUTENBERG, 77600 BUSSY-SAINT-GEORGES – FRANCE

WWW.INGERSOLLRANDPRODUCTS.COM

ARO®

IR Ingersoll Rand®